

**AVAILABLE VERSIONS**

<b>LA</b> Left arm	<b>SA</b> Semiautomatic	<b>ST</b> Static base
<b>RA</b> Right arm	<b>TD</b> Total drive	<b>TW</b> Twister

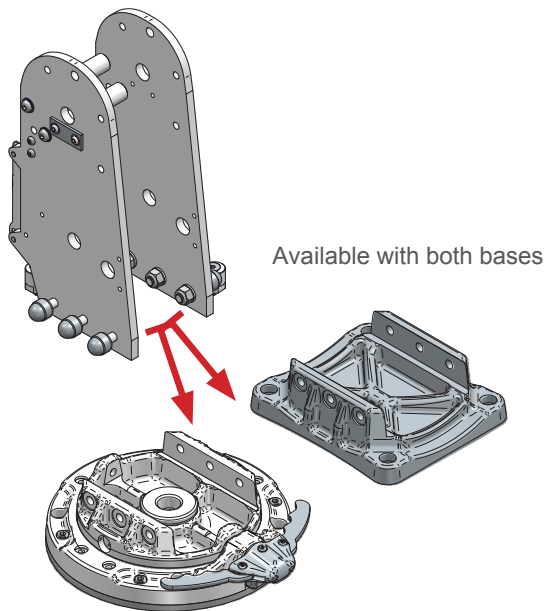

Fiorella F360 Slim Fit leads a new standard for functionality and safety. All functions are integrated in this extraordinary lift to facilitate its use and to make it safe for both the wheelchair occupant and the assistant.



**GENERAL FUNCTIONAL FEATURES**

- Fully automatic fold/unfold of the platform on Total Drive models
- Pump separation kit available
- Wireless remote
- Integrated command keys
- Vehicle-specific mounting brackets

**GENERAL SAFETY FEATURES**

- Anti-fall automatic outboard roll stop
- Automatic inner roll stop
- Blocking system with weight sensor
- Visual and acoustic signalling systems
- Anti-crushing system on main arm
- General protection fuse
- Manual backup system

**CONTROL PANEL LCD DISPLAY**

- Cycle counting indicator for the scheduled maintenance

**TECHNICAL DATA**

		STATIC BASE	TWISTER
MEASUREMENTS	Overall Lift Width	1180 mm	
	Overall Lift Width (separated pump)	985 mm	
	Overall Lift Height (stowed position)	1030 mm	1045 mm
	Usable Platform Width (Max)	714 mm	
	Usable Platform Length (Max)	1030 mm	
TECH-CAPABILITY	Maximum Floor-To-Ground	660 mm	
	Power	Electrohydraulic	
	Motor	12V DC / 58A	
	Max Speed Ascent/Descent	0,06 m/s	
	Max Load Capacity	360kg	
WEIGHT	Lift Weight	119kg	136kg
	Lift Weight (TD)	128kg	145kg

**CERTIFICATIONS**

2006/42/EC	Machinery Directive
2009/19/CE	Electromagnetic Compatibility
EN 1756-2:2009	Platform lifts for mounting on wheeled vehicles - Safety requirements

